

# Roller-Spring

## Spring Roller Blind

A classic roller blind with a streamlined look. Our Stop Springs provide a smooth and quiet operation with positional bearings used to ensure a stopping function, whilst the NO Stop Springs

are designed without bearings to provide a constant pre-tensioned manual operation.



### Technical

- Child Safe - no chains
- Base Rail is only available as fabric wrapped
- High quality plastic & metal
- Quiet operation
- Colour matched brackets & end cover caps
- Easy Lock Idle End for simple installation
- 5 year Component Warranty

- 1 Spring AC & auto idler
- 2 Installation bracket
- 3 Bracket endcover cap
- 4 Aluminium tube

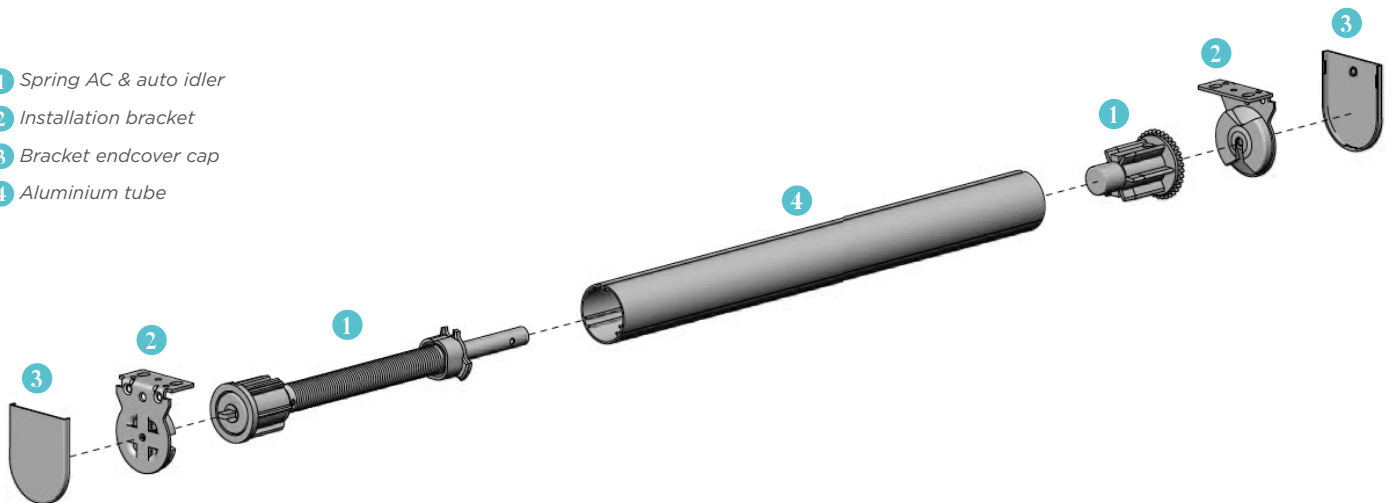

**AMBIENCE**

BLINDS • SHUTTERS • AWNINGS

[www.ambienceblinds.com.au](http://www.ambienceblinds.com.au)

# Roller-Spring

## Spring Roller Blind

### Bracket and End Cap Colour Range

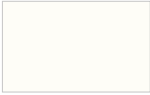

Pure White  
069

### Additional Options

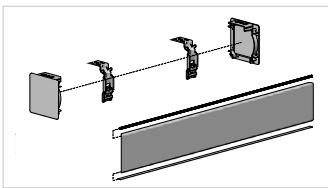

#### Valance System FRS80 or FRS100

Simple headbox concealing blind componentry.  
FRS80: 80mm x 80mm  
FRS100: 100mm x 100mm

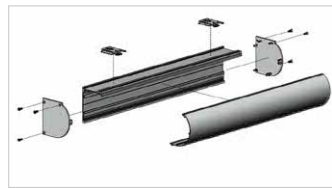

#### Round Cassette Box

70mm deep x 70mm high

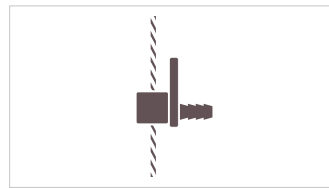

#### Internal Wire Guide

Best used to control sideways movement of blinds.



**AMBIENCE**

BLINDS • SHUTTERS • AWNINGS